

TURBO CLESSIDRA GLASS AQUA 16

16,0 KW - 21,3 KW

COLORS_



CLEAN



TECHNOLOGY



OPTIONAL



Ventilazione Frontale Disattivabile - Uscita Fumi Posteriore

Front Ventilation Deactivatable - Rear Exhaust Fume Outlet - Ventilation Avant Désactivable - Sortie De Fumée Arrière - Ventilación Frontal Disactivable - Salida De Humos Trasera - Deaktivierbares Front Gebläse - Rauchausgang Hinten



Potenza Globale Global Power Puissance globale Potencia global Verbrennungsleistung	Rendimento totale Total efficiency Puissance globale Potencia global Pellet Wirkungsgrad	Potenza all'acqua Water power Puissance à l'eau Potencia al agua Wärmeleistung wassersseitig	Potenza all'ambiente Power Environment Puissance à l'ambient Potencia al ambiente Raumwärmeleistung	Peso Weight Poids Peso Gewicht	Consumo min-MAX Min-Max consumption Consumation min-MAX Consumo min-maxi Min-Maxi Verbrauch	Uscita fumi Chimney Output Sortie conduit de cheminée Salida conducto de humos Rauchauslass	Ingresso aria Air inlet Entrée d'air Entrada aire Lufteinlass	Serbatoio pellet Pellet tank Reservoir Deposito Tank Fassungsvermögen	Pressione d'esercizio Pressure Pression de service Presión de funcionamiento Betriebsdruck	Absorbimento elettrico Electrical consumption Absorption électrique Consumo de electricidad Elektrischer Verbrauch
---	--	--	---	--	---	---	---	---	--	--

KW 18,7-3,4	% 91,6	KW 14,9	KW 3,8	Kg 195	Kg/H 0,7-4,4	mm 80	mm 60	Kg 23	BAR 1,5	W 110
-------------	--------	---------	--------	--------	--------------	-------	-------	-------	---------	-------

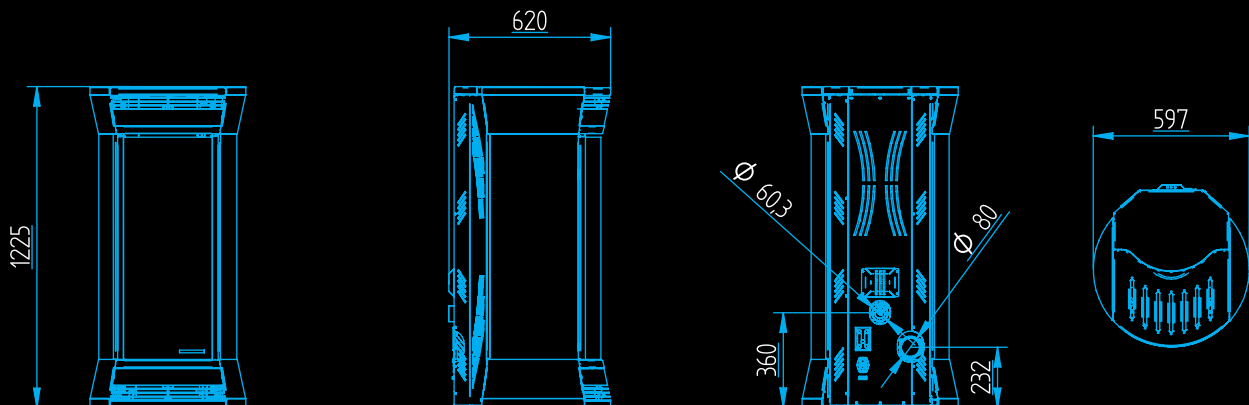

MORETTIDESIGN®